

## ZD-QJJ3|2 2-Post Mechanic Car lift (with base)

### Features

- High resistance chain transmission.
- Main nut and safety nut made of high wear-resistance nylon.
- High resistance rolled steel screws to provide long life.
- Welded tubular structure, nothing sturdier in the world.
- Automatic arm locking during lifting and unlocking when the arm reaches the floor.
- Self supporting base, installation is possible on floor with poor surface anchorage.
- Base with small ramps for easy drive through.
- Asymmetrical arms and posts.

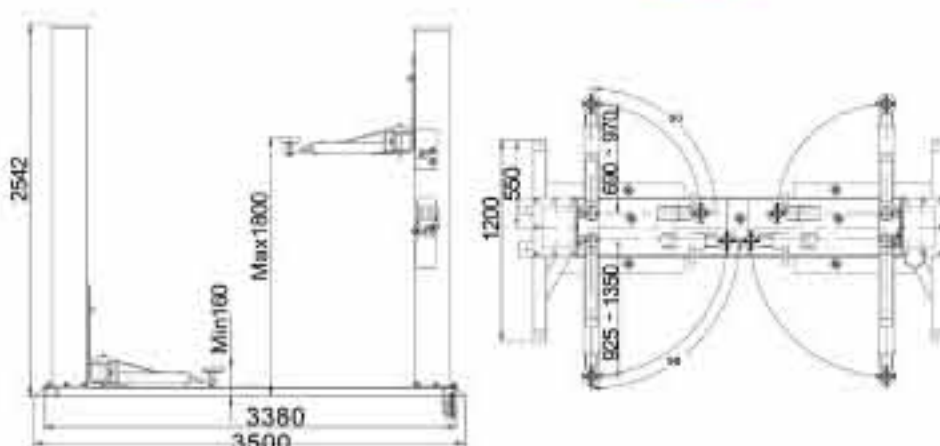

### Technical data

Lifting capacity	3000kg	Drive-thru distance	2135mm
Lifting height	1800mm	Net weight	800Kg
Min. height	120mm	Motor power	3kw
Raising time	≤70s	Power supply	380v/3Ph
Lowering time	≤60s		

## ZD-QJY3|2 2-Post Hydraulic Car lift (with base)

### Features

- Chain lifting system. Anti-breakage safety for chain.
  - Double self-locking protective device.
  - Anti-abrasion nylon slide block for stable lifting.
  - Automatic arm locking during lifting and unlocking when the arm reaches the floor.
  - Self supporting base, installation is possible on floor with poor surface anchorage.
  - Base with small ramps for easy drive through
  - Welded tubular structure, nothing sturdier in the world.
  - Single hydraulic cylinder driving.
  - Asymmetrical arms, symmetrical posts.
- Italian pump station and hydraulic cylinder.

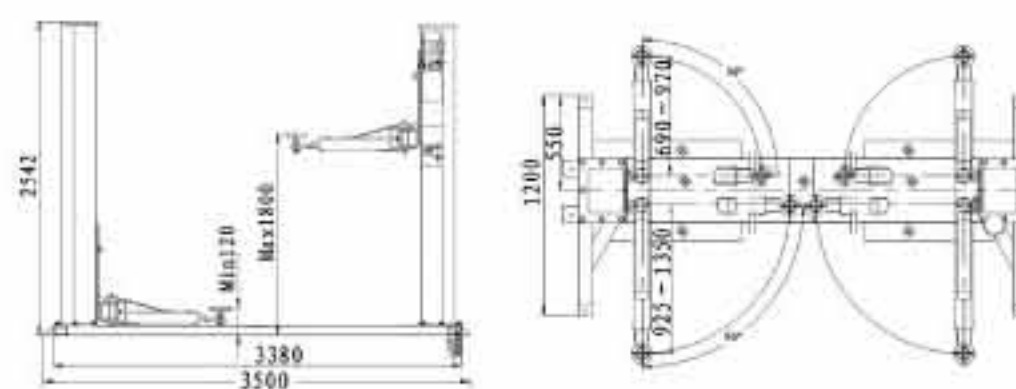

### Technical data

Lifting capacity	3000kg	Drive-thru distance	2832mm
Lifting height	1800mm	Net weight	750Kg
Min. height	120mm	Motor power	2.2kw
Raising time	≤70s	Power supply	380v, 220v
Lowering time	≤60s		



## ZD-QJY3D 2-Post Hydraulic Car lift (with base)

### Features

- Chain lifting system. Anti-breakage safety for chain.
- Double self-locking protective device.
- Anti-abrasion nylon slide block for stable lifting.
- Automatic arm locking during lifting and unlocking when the arm reaches the floor.
- Self supporting base, installation is possible on floor with poor surface anchorage.
- Base with small ramps for easy drive through.
- Folded steel posts with high rigidity.
- Single hydraulic cylinder driving.
- Asymmetrical arms, symmetrical posts.

ZD-QJY3D-1 with Italian pump station, Chinese hydraulic cylinder.

ZD-QJY3D-2 with Chinese pump station, Chinese hydraulic cylinder.  
(Italian cylinder optional)

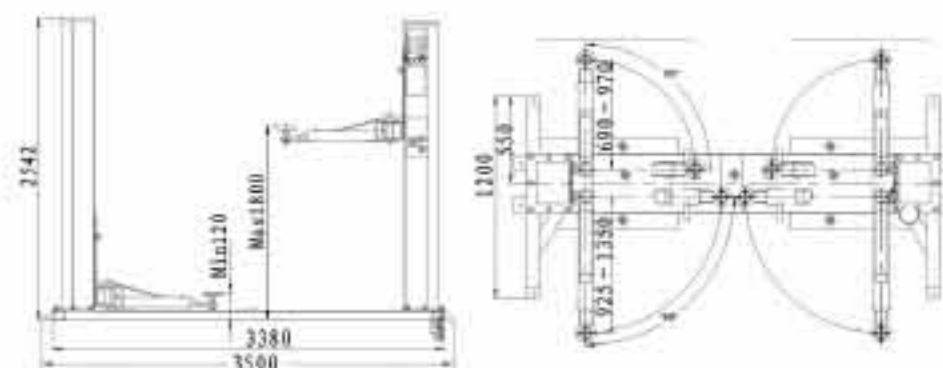

### Technical data

Lifting capacity	3000kg	Drive-thru distance	2832mm
Lifting height	1800mm	Net weight	750Kg
Min. height	120mm	Motor power	2.2kw
Raising time	≤70s	Power supply	380v, 220v
Lowering time	≤60s		

## ZD-QJY320D 2-Post Hydraulic Car lift

### Features

- Chain lifting system. Anti-breakage safety for chain.
- Double self-locking protective device.
- Anti-abrasion nylon slide block for stable lifting.
- Automatic arm locking during lifting and automatic unlocking when the arm reaches the floor.
- Without metal base, posts anchored onto floor.
- With narrow plate on floor to cover the chains.
- Folded steel posts with high rigidity.
- Double hydraulic cylinders to ensure stable moving.
- Manually release safety lock for lowering.
- Asymmetrical arms, symmetrical posts.

ZD-QJY320D-1 with Italian pump station, Chinese hydraulic cylinder.

ZD-QJY320D-2 with Chinese pump station, Chinese hydraulic cylinder.  
(Italian cylinder optional)

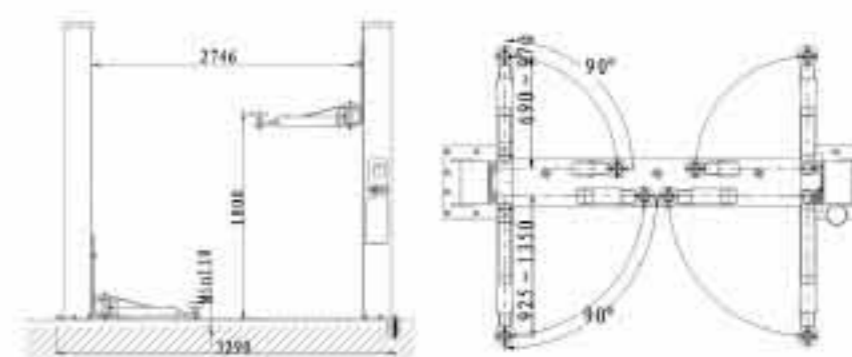

### Technical data

Lifting capacity	3000kg	Drive-thru distance	2746mm
Lifting height	1800mm	Net weight	600Kg
Min. height	110mm	Motor power	2.2kw
Raising time	≤70s	Power supply	380v, 220v
Lowering time	≤60s		